

Manitowoc Cranes

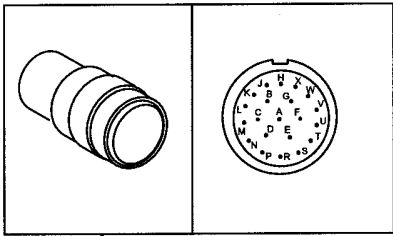

4

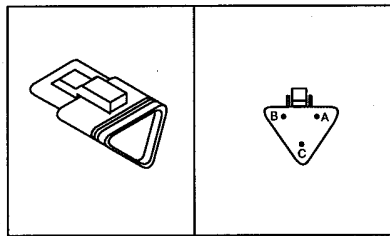

6

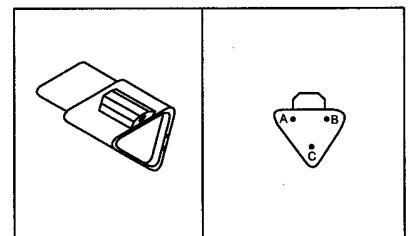

8

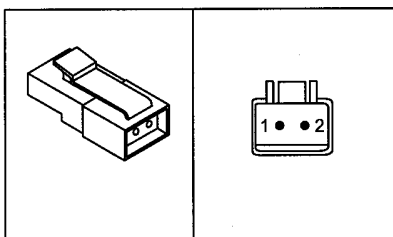

9

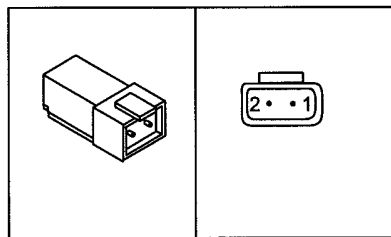

11

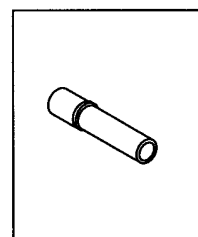

12

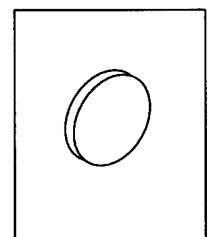

15

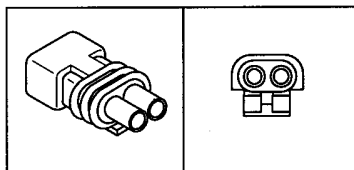

18

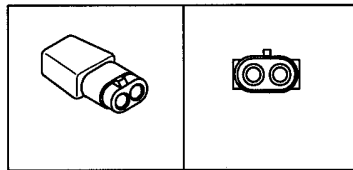

19

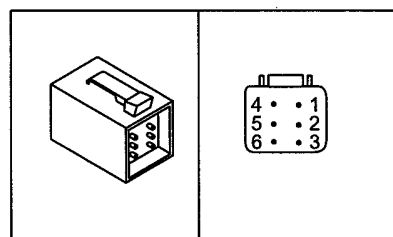

23

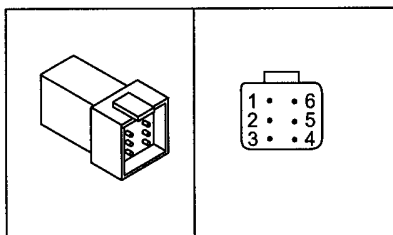

25

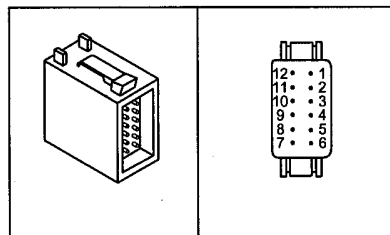

30

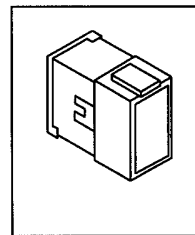

31

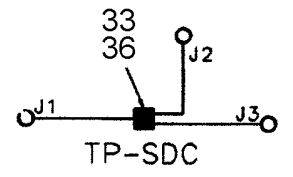

DETAIL **J1-J3**

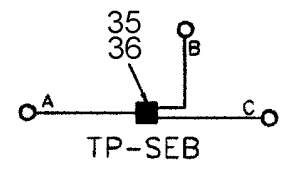

DETAIL **27**

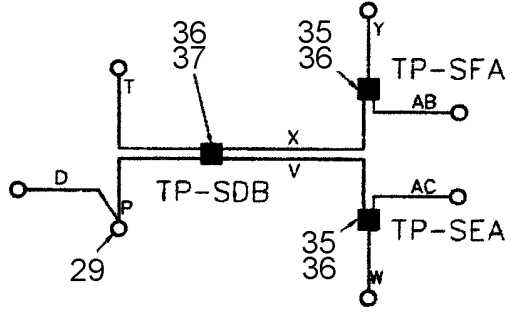

DETAIL **51**

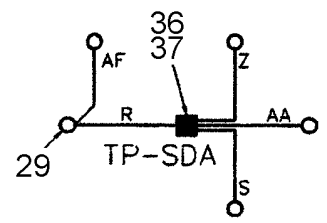

DETAIL **51**

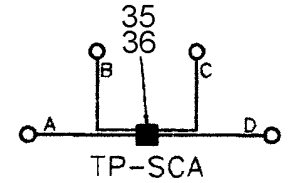

DETAIL **73**

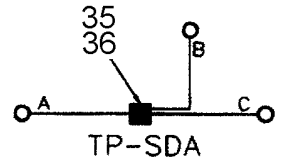

DETAIL **101**

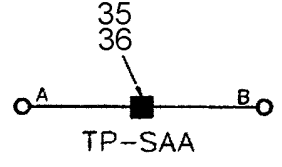

DETAIL **505**

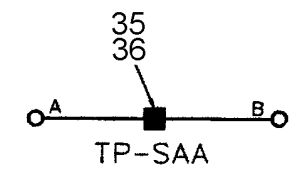

DETAIL **506**

Manitowoc Cranes

| WIRE NO | COLOR | TYPE | SAE SIZE | LENGTH | TP | B/M ITEM NO | REMARKS | TP | B/M ITEM NO | REMARKS |
|---------|-------|------|----------|----------|-----|-------------|-------------|-----|-------------|-------------|
| | | | | TOTAL IN | | | | | | |
| J1 | YEL | SXL | 16 | 3 | DB | 13 | --- | SDC | STRIP | SEE DETAIL |
| J2 | YEL | SXL | 16 | 3 | DB | 13 | --- | SDC | STRIP | SEE DETAIL |
| J3 | YEL | SXL | 16 | 3 | DB | 13 | --- | SDC | STRIP | SEE DETAIL |
| 27A | YEL | SXL | 16 | 166 | AA | 13 | --- | SEB | STRIP | SEE DETAIL |
| 27B | YEL | SXL | 16 | 22 | SEB | STRIP | SEE DETAIL | EA | 12 | --- |
| 27C | YEL | SXL | 16 | 54 | SEB | STRIP | SEE DETAIL | FA | 12 | --- |
| 47 | YEL | SXL | 16 | 181 | AA | 13 | --- | EB | 12 | --- |
| 48 | YEL | SXL | 16 | 210 | AA | 13 | --- | FB | 12 | --- |
| 49 | YEL | SXL | 14 | 132 | AA | 13 | --- | DB | 12 | --- |
| 50 | YEL | SXL | 16 | 102 | AA | 13 | --- | CC | 12 | --- |
| 51C | YEL | SXL | 12 | 105 | G1 | 29 | --- | BC | 21,22 | --- |
| 51D | YEL | SXL | 14 | 130 | G1 | STRIP | SEE DETAIL | CD | 12 | --- |
| 51E | YEL | SXL | 16 | 6 | CC | 12 | --- | CD | 12 | --- |
| 51F | YEL | SXL | 16 | 6 | CC | 12 | --- | CD | 12 | --- |
| 51G | YEL | SXL | 16 | 18 | CB | 12 | --- | CD | 12 | --- |
| 51H | YEL | SXL | 16 | 18 | CB | 12 | --- | CD | 12 | --- |
| 51J | YEL | SXL | 16 | 18 | CB | 12 | --- | CD | 12 | --- |
| 51K | YEL | SXL | 16 | 30 | CA | 12 | --- | CD | 12 | --- |
| 51L | YEL | SXL | 16 | 30 | CA | 12 | --- | CD | 12 | --- |
| 51M | YEL | SXL | 16 | 30 | CA | 12 | --- | CD | 12 | --- |
| 51N | YEL | SXL | 16 | 101 | CD | 12 | --- | BA | STRIP | CRIMP W/51U |
| 51P | YEL | SXL | 14 | 158 | G1 | STRIP | SEE DETAIL | SDB | STRIP | SEE DETAIL |
| 51R | YEL | SXL | 12 | 160 | G1 | STRIP | SEE DETAIL | SDA | STRIP | SEE DETAIL |
| 51S | YEL | SXL | 16 | 4 | DA | 12 | --- | SDA | STRIP | SEE DETAIL |
| 51T | YEL | SXL | 14 | 4 | DB | 12 | --- | SDB | STRIP | SEE DETAIL |
| 51U | YEL | SXL | 16 | 78 | BA | 17 | CRIMP W/51N | BB | 28 | --- |
| 51V | YEL | SXL | 16 | 42 | SDB | STRIP | SEE DETAIL | SEA | STRIP | SEE DETAIL |
| 51W | YEL | SXL | 16 | 16 | SEA | STRIP | SEE DETAIL | EA | 12 | --- |
| 51X | YEL | SXL | 16 | 71 | SDB | STRIP | SEE DETAIL | SFA | STRIP | SEE DETAIL |
| 51Y | YEL | SXL | 16 | 19 | FA | 12 | --- | SFA | STRIP | SEE DETAIL |
| 51Z | YEL | SXL | 14 | 4 | DA | 21,22 | --- | SDA | STRIP | SEE DETAIL |
| 51AA | YEL | SXL | 14 | 4 | DA | 21,22 | --- | SDA | STRIP | SEE DETAIL |
| 51AB | YEL | SXL | 16 | 11 | FB | 12 | --- | SFA | STRIP | SEE DETAIL |
| 51AC | YEL | SXL | 16 | 11 | EB | 12 | --- | SEA | STRIP | SEE DETAIL |
| 51AD | YEL | SXL | 16 | 12 | CD | 12 | --- | CE | 12 | --- |
| 51AE | YEL | SXL | 16 | 12 | CD | 12 | --- | CE | 13 | --- |
| 51AF | YEL | SXL | 16 | 153 | G1 | STRIP | SEE DETAIL | CF | 12 | --- |
| 67 | YEL | SXL | 14 | 25 | AA | 13 | --- | BA | 17 | --- |
| 73A | YEL | SXL | 14 | 122 | AA | 13 | --- | SCA | STRIP | SEE DETAIL |
| 73B | YEL | SXL | 16 | 14 | CB | 12 | --- | SCA | STRIP | SEE DETAIL |
| 73C | YEL | SXL | 16 | 4 | CA | 12 | --- | SCA | STRIP | SEE DETAIL |
| 73D | YEL | SXL | 16 | 4 | CA | 12 | --- | SCA | STRIP | SEE DETAIL |
| 74 | YEL | SXL | 16 | 136 | AA | 13 | --- | DA | 12 | --- |
| 87 | YEL | SXL | 12 | 77 | AA | 14 | --- | BC | 21,22 | --- |
| 89A | YEL | SXL | 16 | 34 | BB | 16 | --- | BC | 12 | --- |
| 92 | YEL | SXL | 16 | 77 | AA | 13 | --- | BC | 12 | --- |
| 93 | YEL | SXL | 16 | 77 | AA | 13 | --- | BC | 12 | --- |
| 101A | YEL | SXL | 12 | 131 | AA | 14 | --- | SDA | STRIP | SEE DETAIL |
| 101B | YEL | SXL | 14 | 5 | SDA | STRIP | SEE DETAIL | DA | 21,22 | --- |
| 101C | YEL | SXL | 14 | 5 | SDA | STRIP | SEE DETAIL | DA | 21,22 | --- |
| 209 | YEL | SXL | 14 | 125 | AA | 13 | --- | CF | 12 | --- |
| 338 | YEL | SXL | 16 | 132 | AA | 13 | --- | DB | 12 | --- |
| 505A | YEL | SXL | 12 | 4 | AA | 14 | --- | SAA | STRIP | SEE DETAIL |
| 505B | YEL | SXL | 14 | 128 | DB | 12 | --- | SAA | STRIP | SEE DETAIL |
| 506A | YEL | SXL | 12 | 6 | AA | 14 | --- | SAA | STRIP | SEE DETAIL |
| 506B | YEL | SXL | 14 | 108 | CB | 12 | --- | SAA | STRIP | SEE DETAIL |
| 507 | YEL | SXL | 16 | 164 | CB | 12 | --- | DB | 12 | --- |
| 508 | YEL | SXL | 16 | 188 | AA | 13 | --- | EA | 12 | --- |
| 509 | YEL | SXL | 16 | 220 | AA | 13 | --- | FA | 12 | --- |
| 780 | YEL | SXL | 16 | 126 | AA | 13 | --- | CA | 12 | --- |
| 795 | YEL | SXL | 16 | 102 | AA | 13 | --- | CC | 12 | --- |

Manitowoc Cranes

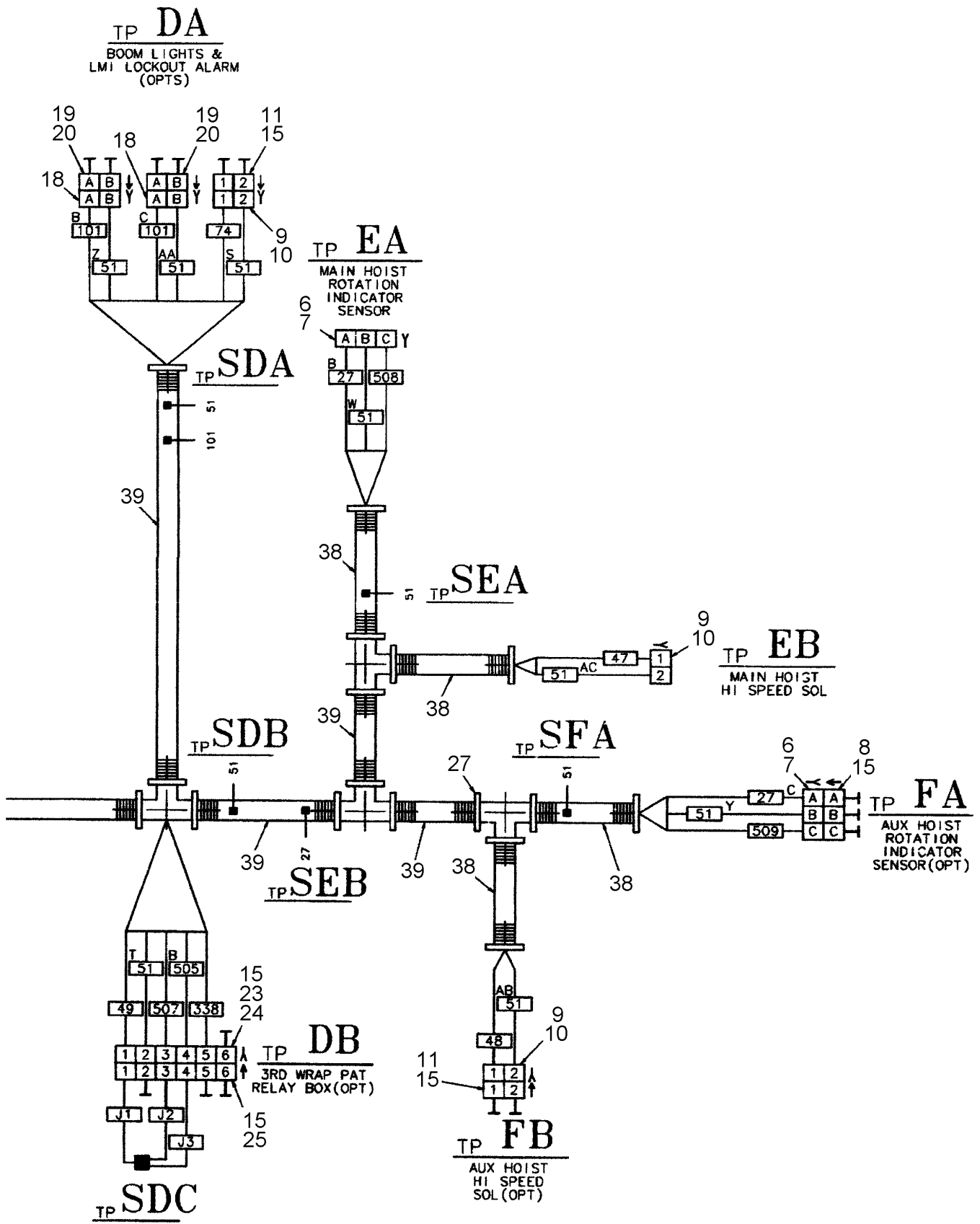

6512100471

(SHEET 2 OF 5)

Manitowoc Cranes

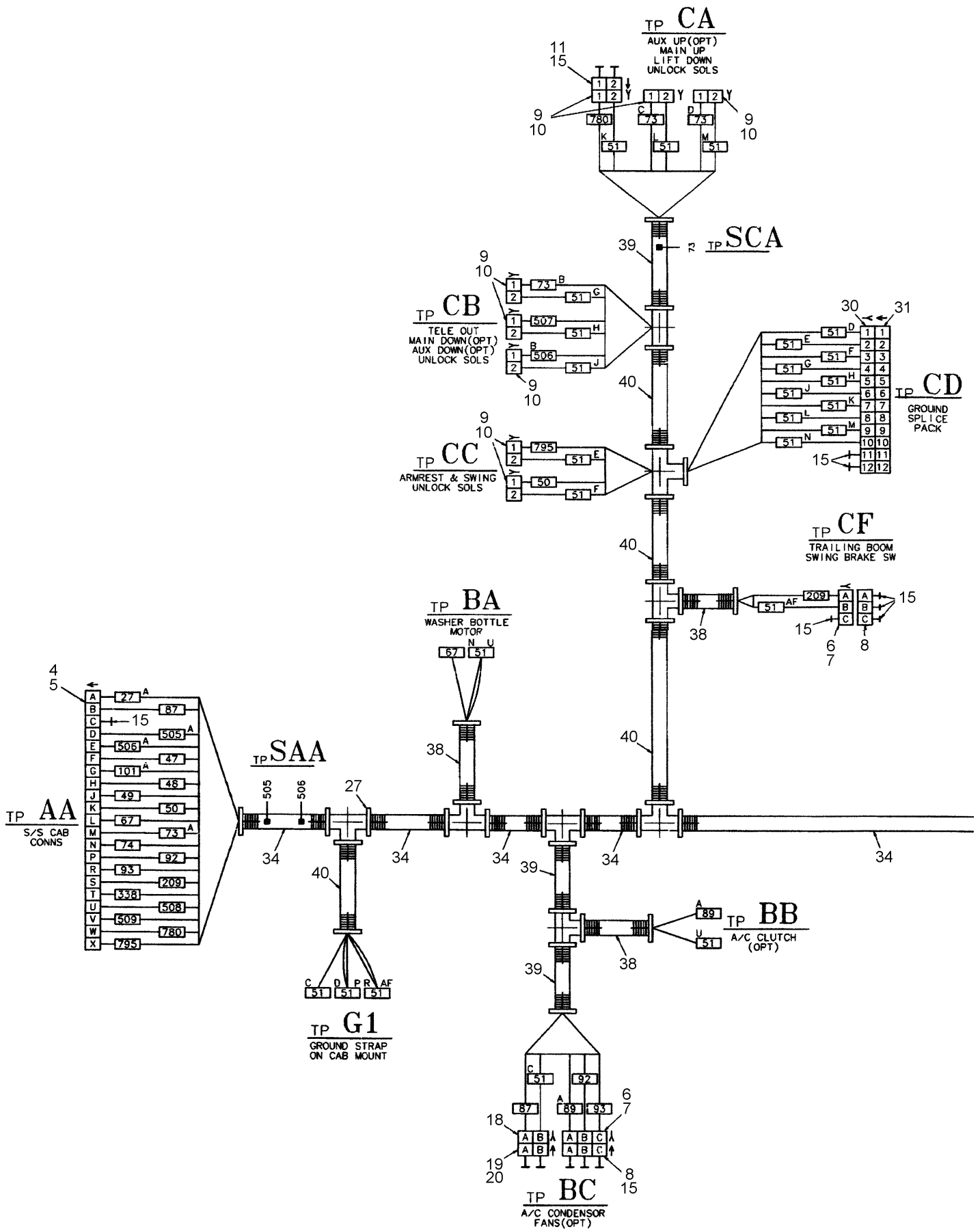

6512100471

(SHEET 1 OF 5)